

MICROMAC PHOSPHATE

ON LINE ANALYZER FOR PHOSPHATE MONITORING IN WATER



MICROMAC PHOSPHATE is a microprocessor controlled On Line analyzer specifically designed for automatic phosphate monitoring on several types of waters matrix.

✓ ROBUST AND RELIABLE

Designed for industrial and Environmental On Line applications ensures the highest level of robustness in the electronics, mechanics and hydraulics components. Complete separation between electronics and hydraulics plus a simple and robust LFA * hydraulics allows easy maintenance and long terms reliable operations.

* *LFA: Loop Flow Analysis patent pending*

✓ EASY TO INSTALL

The analyzer is delivered after a long and successful series of factory tests ready for installation and setup; it is provided with complete set of spares for start up. To start monitoring is enough to connect reagents, sample line, waste line and power supply.

✓ AUTOMATIC CALIBRATION

When the Calibration Time interval expires the analyzer performs a Calibration Cycle, storing and checking the new calibrant O. D. If new O.D. exceeds selected limits, an alarm contacts is closed.

✓ SAMPLE DILUTION

Sample can be analyzed as it is or after automatic dilution. Automatic dilution is factory adjusted for high range applications.

✓ MEASURING INTERVAL

User selectable; between two measurements the analyzer remains in stand by mode, without reagents consumption.

✓ FEATURES AND BENEFITS

- Fully automatic operation
- Long autonomy; low maintenance, low operating cost
- Low reagents consumption; short preparation time; low disposable costs
- Easy operation; plug in analyzer, no special training is required
- Electronics and hydraulics completely separated
- Serial interface for local o remote PC connection (option)

PO4 measuring principle and hydraulic diagram

The sample after proper filtration is pumped inside the LFA reactor, where the analyzer measure and store the sample blank. The microprocessor starts the reagents addition sequence, adding as first the Acidic Molybdate, to form the phosphomolybdate complex. After a proper mixing time, the analyzer introduces the ascorbic acid reducing agent, necessary for the colorimetric reaction. After a further mixing step and reaction time the analyzer stops the reaction product inside the flow cell, where it measures the absorbance at 660 or 880 nm. The sample concentration is calculated against the calibration factor stored in the analyzer.

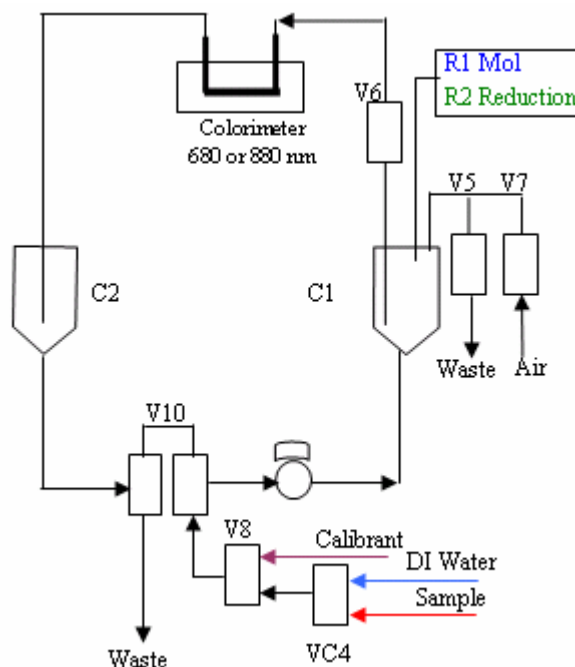

Technical Specifications

MEASURING PRINCIPLE: Colorimetric, Molybdate ascorbic acid method

COLORIMETER: dual beam, silicon detector

MEASUREMENT TYPE: cyclic

MEASURING INTERVAL: programmable

MEASURING TIME: 5 minutes

MEASURING RANGE: 0-0.2/0.7/2/5/10/20/100/200 ppm P-PO₄, other ranges available on request

DETECTION LIMIT: typically better 2% of the full scale, calculated as for EPA p. 136 appendix

REPEATABILITY: better than 2%

OUTPUT SIGNAL: 4-20 mA **INPUT SIGNALS:** n. 1 Analysis, n. 1 calibration; digital contacts

ALARMS: n. 1 High Limit, n. 1 General, n. 1 Calibration; potential free contacts

SAMPLE AND WASTE DELIVERY: pressure free; **SAMPLE TEMPERATURE:** 10 °C - 30 °C

REAGENTS REPLACEMENT: 3/4 weeks depending on the operating temperature

PROTECTION: IP55

HARDWARE: PC104 industrial standard, Integrated keyboard and graphics display, RS232 option

POWER SUPPLY: 12 V DC external power supply from local power to 12 V DC included

WEIGHT: 33 Kg without reagents ; **DIMENSION:** 800x450x300 mm(hxwxwd)

Subject to change without notice



SYSTEA S.p.A.

HEADQUARTER AND MANUFACTURING FACILITY:

VIA PADUNI, 2A - 03012 ANAGNI (FR) ITALY

TEL: +39 0775-776058 FAX +39 0775-772204

A member of Consorzio NDI

Web Site: <http://www.systea.it> Email: info@systea.it

Document ID: MicC_Phosphate-04-E